

# STIGA PARK

---

100 B

---

8211-3014-08



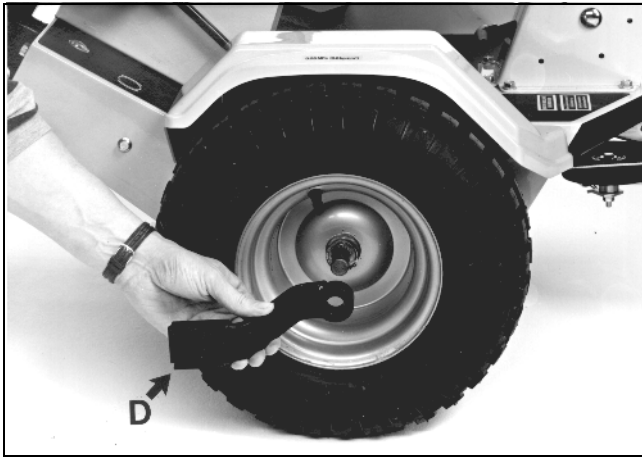

1.

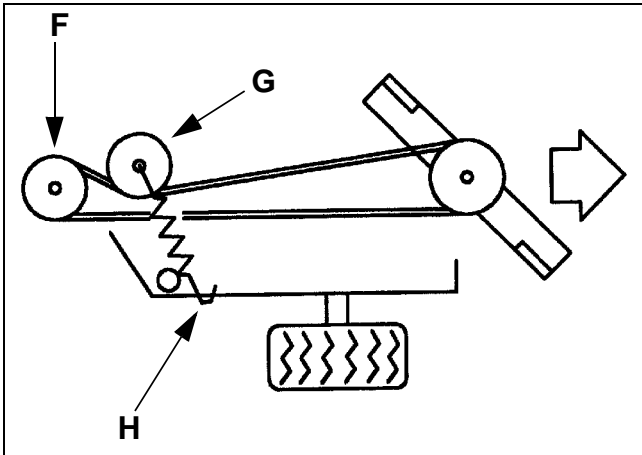

2.

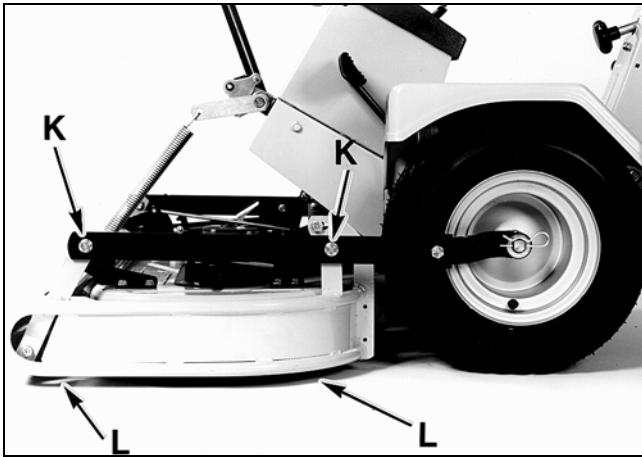

3.

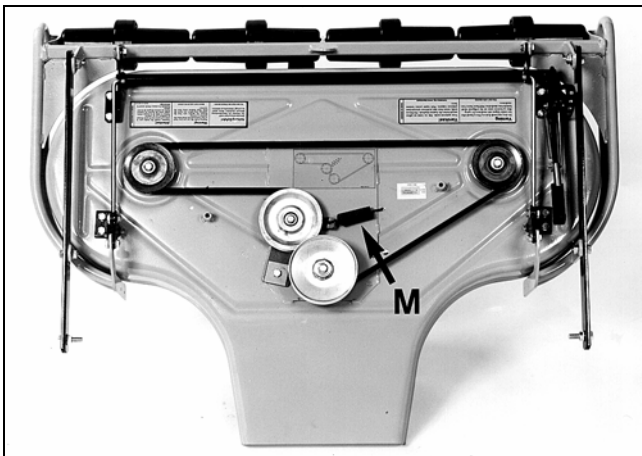

4.

## SYMBOLS

The following symbols are displayed on the machine in order to remind you about the safety precautions and attention necessary when using the machine.

The symbols mean:



Warning!

Read the instruction and safety manual before using the machine.



Warning!

Do not put hands or feet under the cover of the machine when it is running.



Warning!

Beware of objects being flung out. Keep spectators away.



Warning!

Before starting any repair work, remove the spark plug cable from the spark plug.



---

## ASSEMBLING

---

### MOWER DECK

1. Fit the attachments D on the front axle projections by means of washers and locking clips (fig 1).
2. Fit the attaching arms of the mower deck on the attachments on the machine.
3. Place on the v-belt between the belt pulley of the mower deck and the centre belt pulley F of the machine (fig 2).
4. The tensioning roller G should come on the left side of the belt as viewed from the driving seat (fig 2)
5. Then pull the mower deck forwards so that the holes in the attaching arms come in line with the holes in the attachments on the machine.
6. Fit the bolts and tighten them.

7a. Park -1999:

Hook the tension roller spring H into the floor on the right-hand side (fig 2).

7b. Park 2000-

Hook the tension roller spring H into the fastener, just behind the front right wheel (fig 2).

8. Lift up the mower deck and hook the spring on the implement lifting bar.

When changing the v-belt or removing the mower deck, proceed in the reverse order.

### ADJUSTING

1. Make sure that the tyres have the correct inflation pressure:

Front: 0,6 bar (9 psi).

Rear: 0,4 bar (6 psi).

2. Stand the machine on a level floor. Slacken the screws K and adjust the mower deck so that the front and rear edges L come at the same distance from the floor (fig 3). Tighten the screws.

Points 1 and 2 must be carried out to ensure that the mower deck mows evenly.

---

## USE

---

### MOWING HEIGHT

The mower deck has 5 fixed mowing heights, from 40 mm to 80 mm.

N.B. The stated mowing heights apply when the machine is standing on firm ground.

### MOWING HINTS

For the best effect follow this advice:

- mow regularly.
- use full throttle on the engine.
- keep the underside of the mower deck clean.
- use sharp blades.
- do not mow wet grass.

---

## MAINTENANCE

---



**Neither the motor nor the mower deck may be serviced unless:**

- the motor is shut off.
- the ignition key is removed.
- the ignition cable is removed from the spark plug.
- the parking brake is engaged.
- the mower deck is disengaged.

## CLEANING

Each time after mowing wash off the underside of the mower deck casing with a garden hose.

If grass has dried on, remove the mower deck and scrape the underside clean.

If necessary, touch-up the underside with paint to avoid rusting.

## CHANGING DRIVE BELT BETWEEN CENTRE BELT PULLEY AND MOWER DECK

1. Unhook the tension roller spring H (fig 2).
2. Unbolt the mower deck from the machine.
3. Push in the deck towards the machine.
4. Change the faulty v-belt. Always use a genuine belt. The tensioning roller G should come on the left side of the v-belt as viewed from the driving seat (fig 2).
5. Bolt the mower deck on the attachments on the machine.
- 6a. Park -1999:  
Hook the tension roller spring H into the floor on the right-hand side (fig 2).
- 6b. Park 2000-  
Hook the tension roller spring H into the fastener, just behind the front right wheel (fig 2).

## CHANGING DRIVE BELT IN MOWER DECK

1. Remove the mower deck from the machine.
2. Remove the transmission casing over the mower deck.
3. Release the spring M which holds the tensioning roller (fig 4).
4. Change the v-belt and assemble in the reverse order. Always use a genuine belt.

## BLADES

Make sure the blades are always sharp. This gives the best mowing results.

### SHARPENING

For safety reasons the blades must not be sharpened on an emery wheel. Incorrect sharpening (= high temperature) can result in the blades becoming brittle.

When the blades are due to be sharpened, the wet grinding method with a waterstone or grindstone is to be used.



**Following sharpening, the blades must be balanced to avoid vibration damage.**

### CHANGING BLADES

Always use original spare parts when changing the blades, blade attachments or bolts.



**Always use original spare parts. Using non-original spare parts can result in the risk of damage even if they fit in the machine.**

When changing the blades, the blades central bolt should also be replaced. It is provided with a locking device. The blade bolts torque: 65 Nm.

---

## SPARE PARTS

---

STIGA original spare parts and accessories are constructed exclusively for STIGA machines. Note that non original spare parts and accessories have not been checked or approved by STIGA.



**Usage of such parts and accessories can influence the machines operability and safety. STIGA cannot be held responsible for injuries caused by these products.**

*STIGA reserves the right to modify the product without prior notice.*



MOWING AHEAD

BOX 1006 · SE-573 28 TRANÅS

[www.stiga.com](http://www.stiga.com)